

Sinusoidal Antenna
3 dBi Typ. Gain, 2-18 GHz Frequency Range

Planar Spiral Antenna Data Sheet

RM-SIA218-3

Descriptions

RF MISO's **Model RM-SIA218-3** is a 45° slant linear antenna that operates from 2-18GHz. The antenna offers a gain 3 dBi Typ. and low VSWR 2:1 Typ. with SMA-Female connector. This high-performance, ultra-wideband antenna is particularly well-suited for applications such as electronic warfare, airborne arrays, and broadband direction finding.

Specifications

RM-SIA218-3		
Parameters	Typical	Units
Frequency Range	2-18	GHz
Gain	4 Typ.	dBi
VSWR	1.8 Typ.	
3dB Beamwidth, E-Plane	75.79 Typ.	°
3dB Beamwidth, H-Plane	75.47 Typ.	°
Beam Squint(Typ.)	<5	°
Amplitude Matching(Typ.)	<0.5	dB
Phase matching(Typ.)	<5	°
Cross Polarization(Typ.)	<-20	dB
Side Lobe Level(Typ.)	<-25	dB
Front to Back Ratio(Typ.)	>35	dB
Polarization	45° Slant Linear	
Connector	SMA-Female	
Power Handling	5	W
Temperature	-55 to +85	°C
Size(L*W*H)	Ø98.0*90.0	mm
Weight	0.286	Kg

Sinusous Antenna
3 dBi Typ. Gain, 2-18 GHz Frequency Range

Planar Spiral Antenna Data Sheet

RM-SIA218-3

Outline Drawing

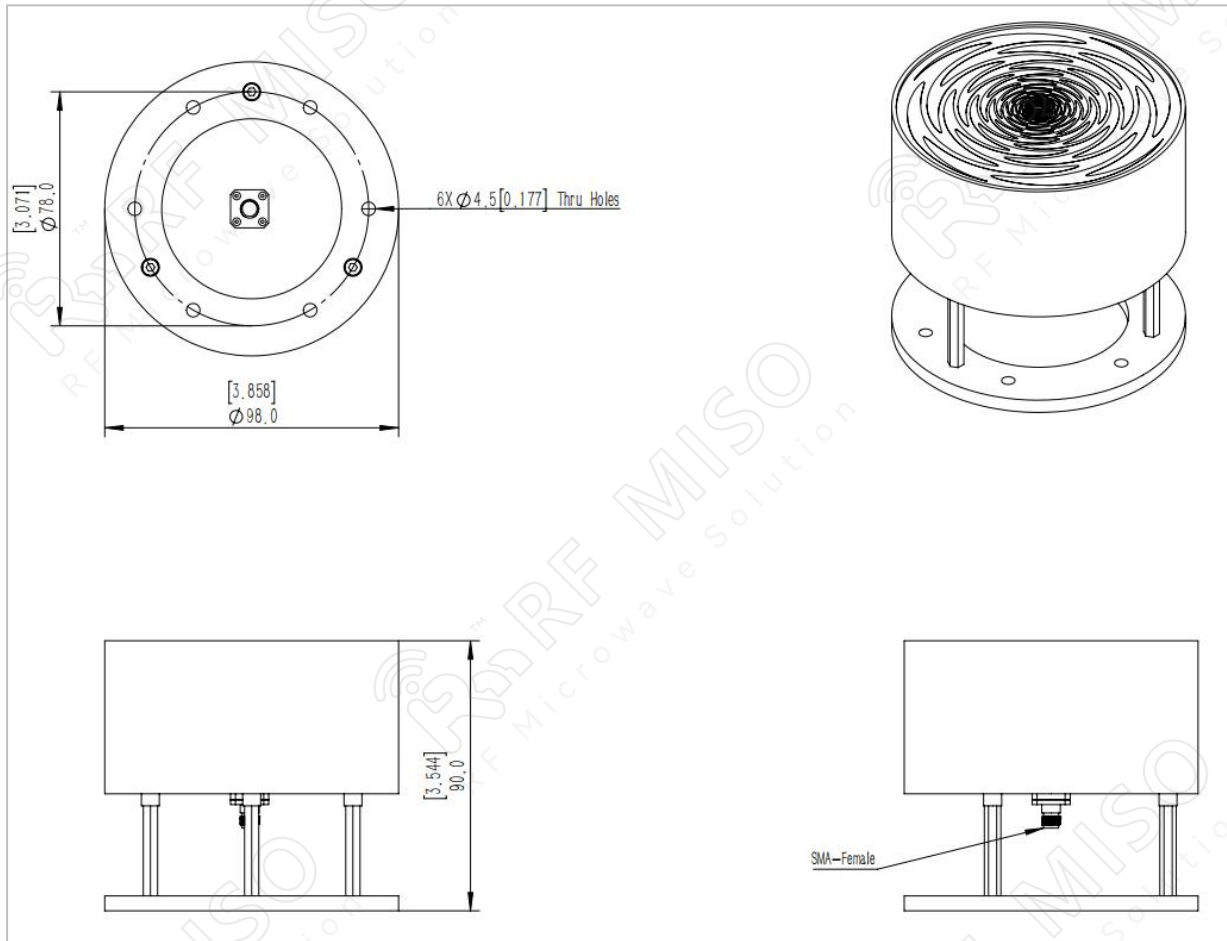

Sinusuous Antenna
3 dBi Typ. Gain, 2-18 GHz Frequency Range

Planar Spiral Antenna Data Sheet

RM-SIA218-3

VSWR

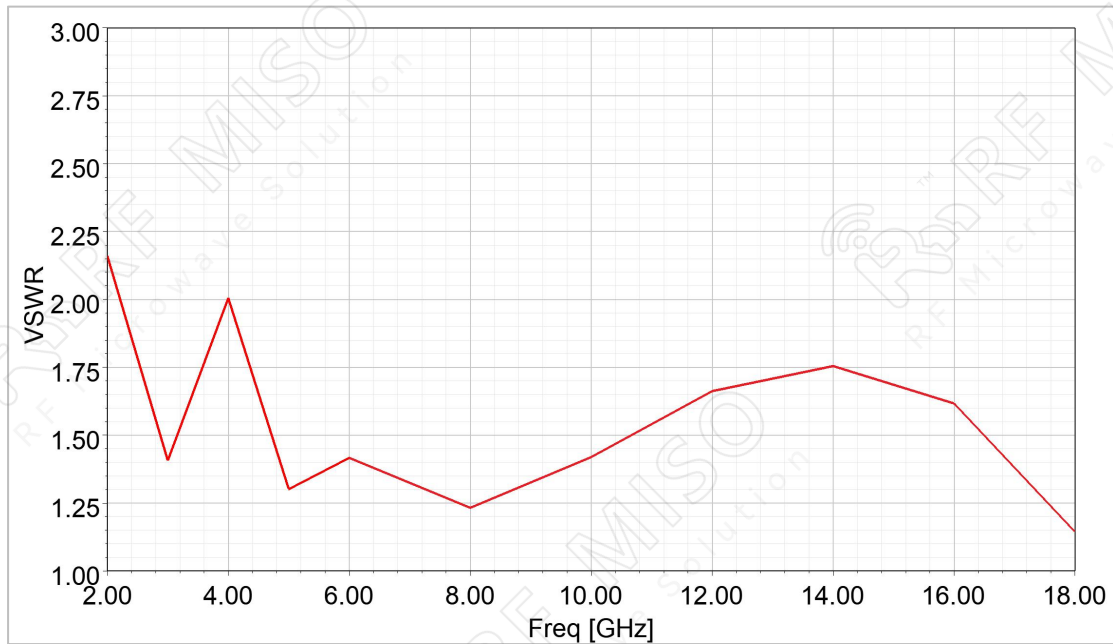

Gain

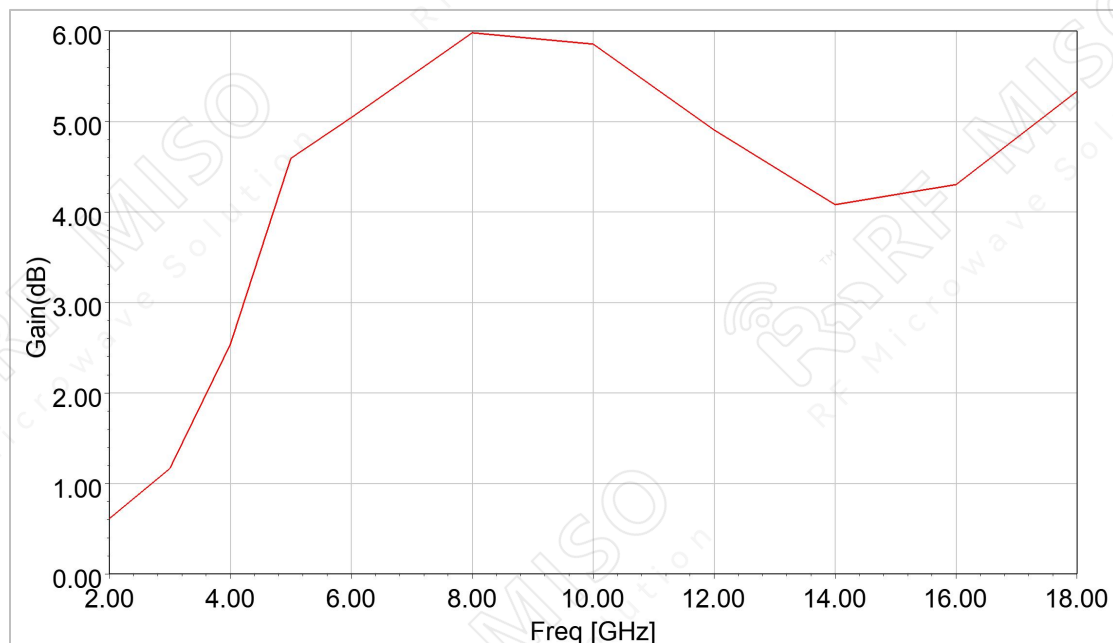

Sinusous Antenna
3 dBi Typ. Gain, 2-18 GHz Frequency Range

Planar Spiral Antenna Data Sheet

RM-SIA218-3

Pattern: 0deg-E-Plane, 90deg-H-Plane

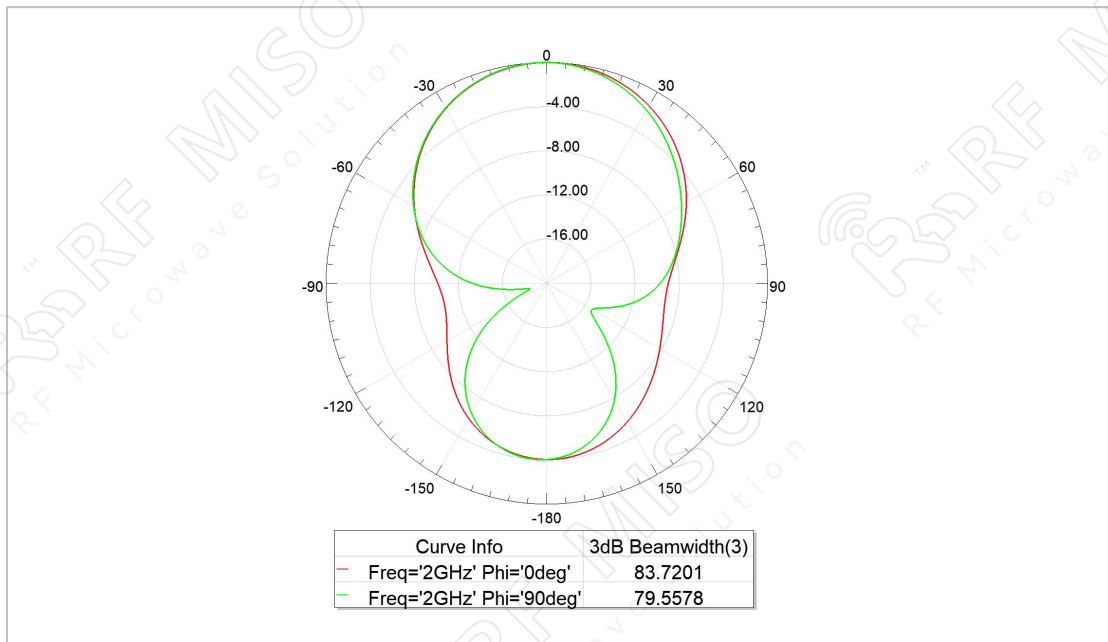

2 GHz

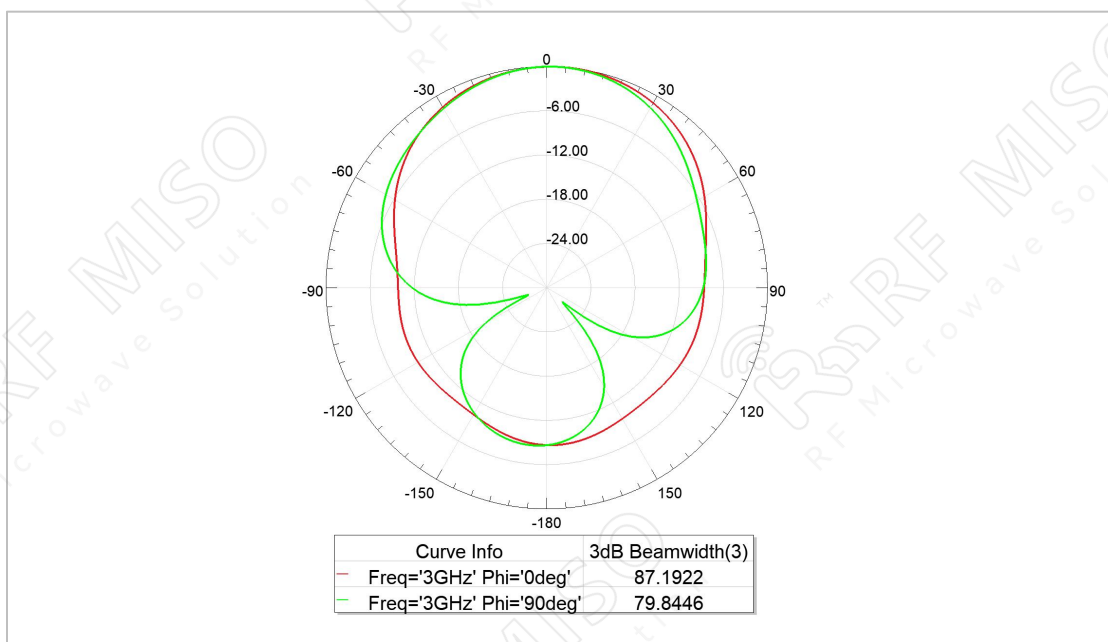

3 GHz

Sinusous Antenna
3 dBi Typ. Gain, 2-18 GHz Frequency Range

Planar Spiral Antenna Data Sheet

RM-SIA218-3

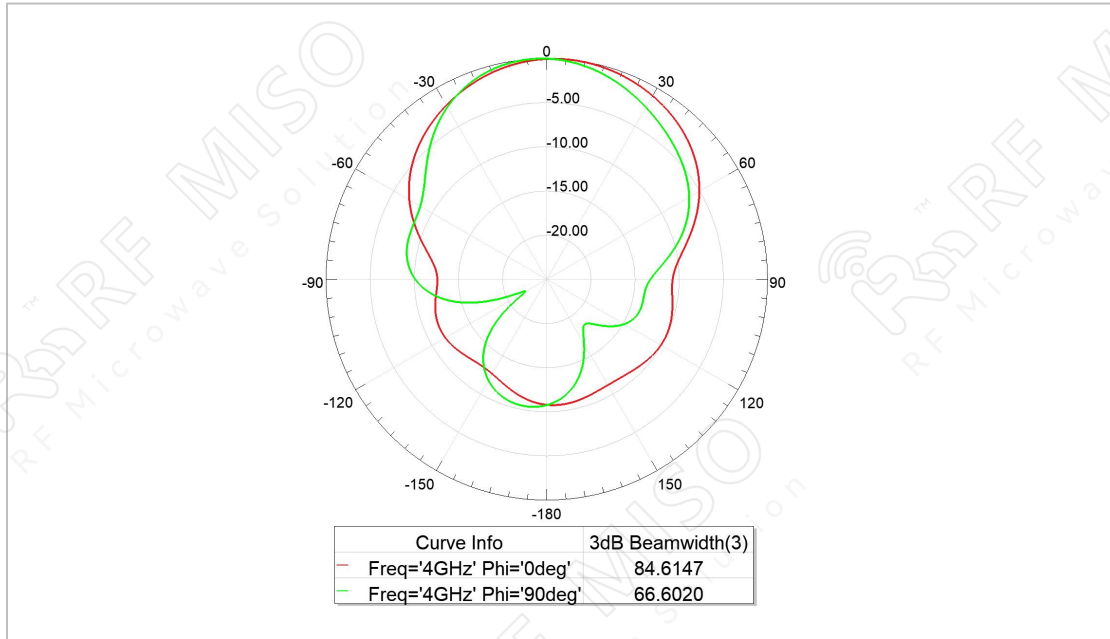

4 GHz

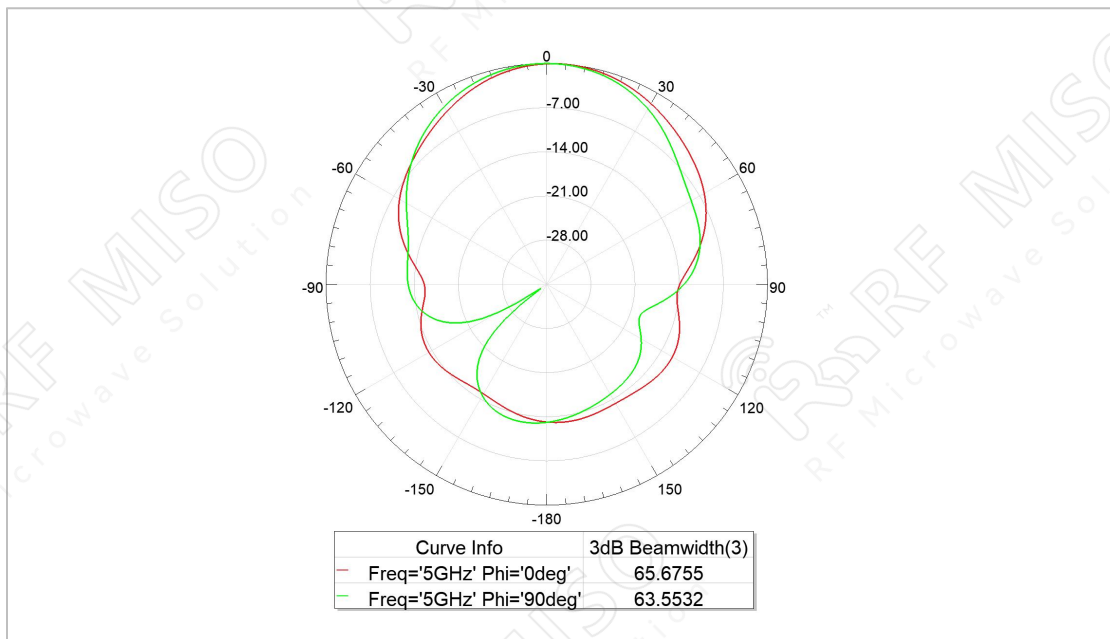

5 GHz

Sinusous Antenna
3 dBi Typ. Gain, 2-18 GHz Frequency Range

Planar Spiral Antenna Data Sheet

RM-SIA218-3

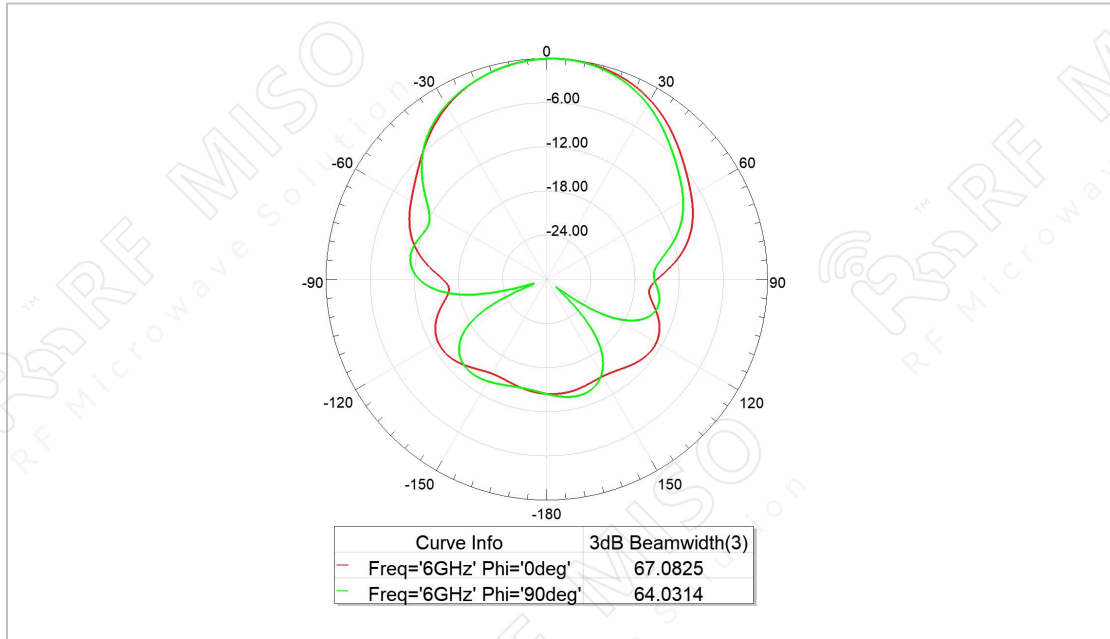

6 GHz

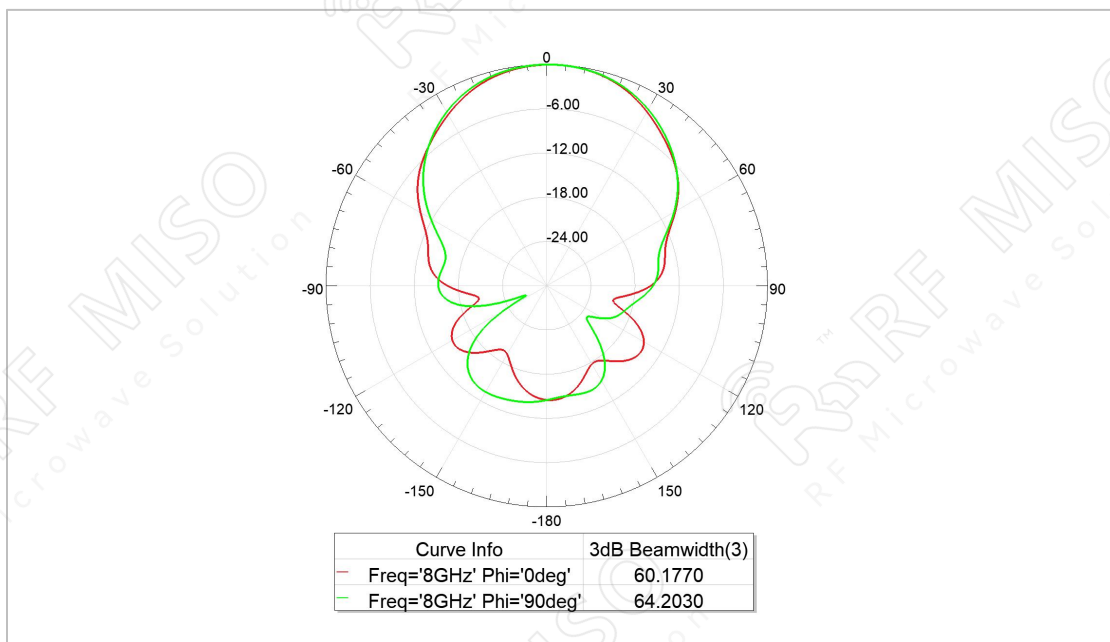

8 GHz

Sinusous Antenna
3 dBi Typ. Gain, 2-18 GHz Frequency Range

Planar Spiral Antenna Data Sheet

RM-SIA218-3

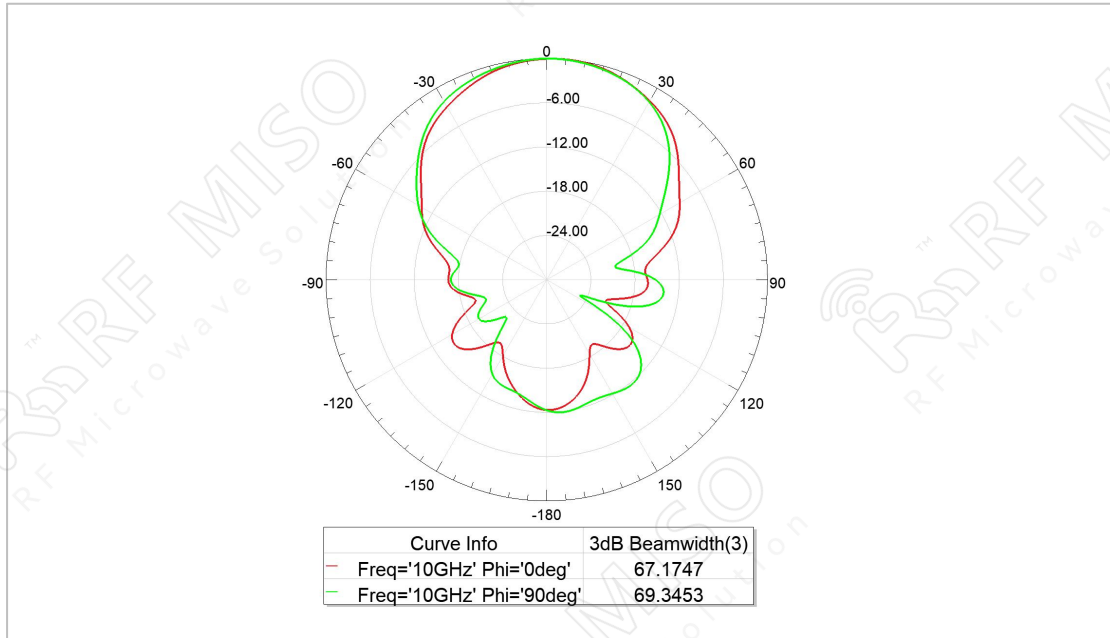

10 GHz

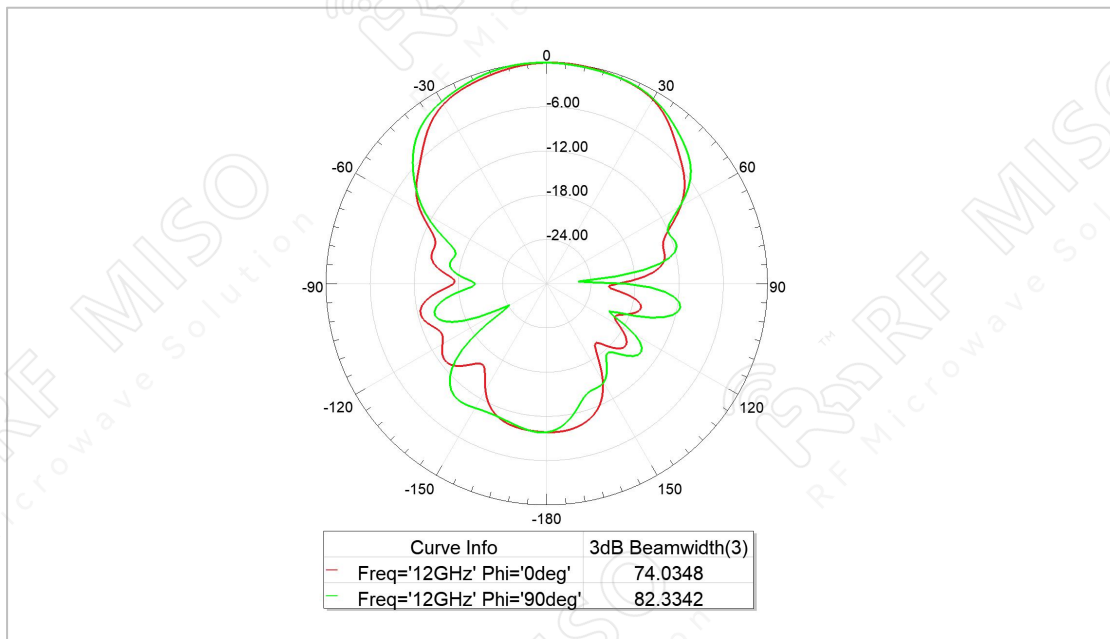

12 GHz

Sinusous Antenna
3 dBi Typ. Gain, 2-18 GHz Frequency Range

Planar Spiral Antenna Data Sheet

RM-SIA218-3

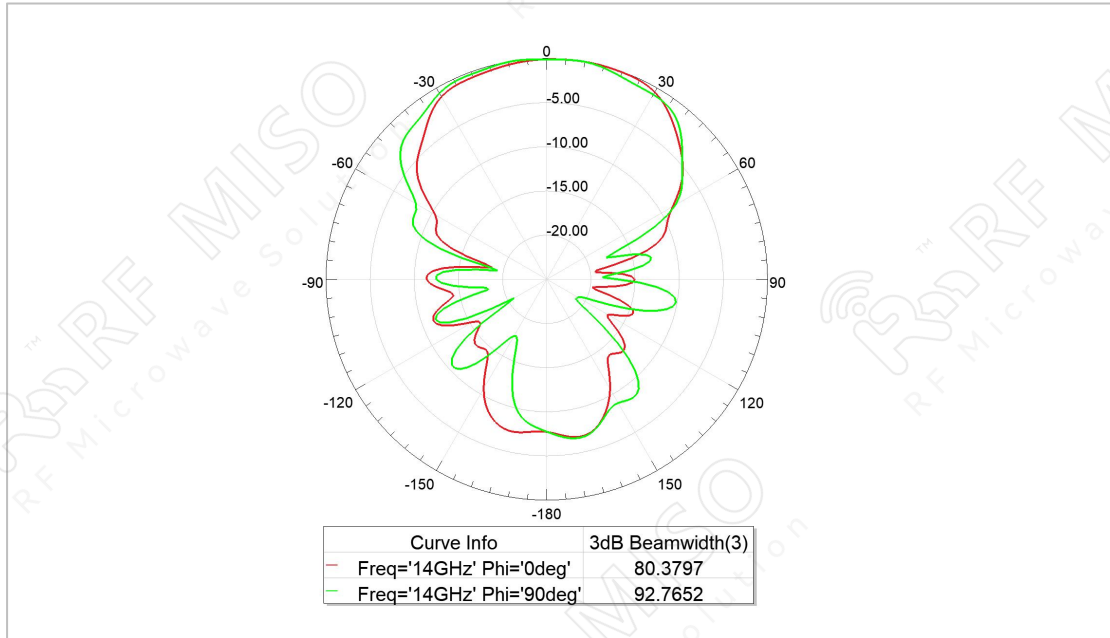

14 GHz

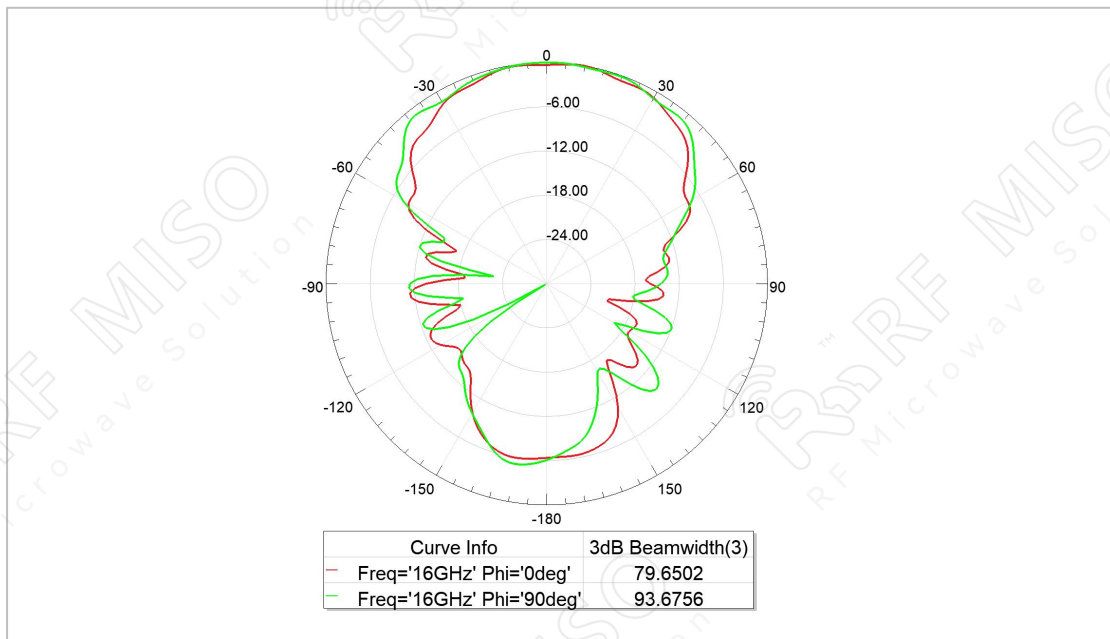

16 GHz

Sinusous Antenna
3 dBi Typ. Gain, 2-18 GHz Frequency Range

Planar Spiral Antenna Data Sheet

RM-SIA218-3

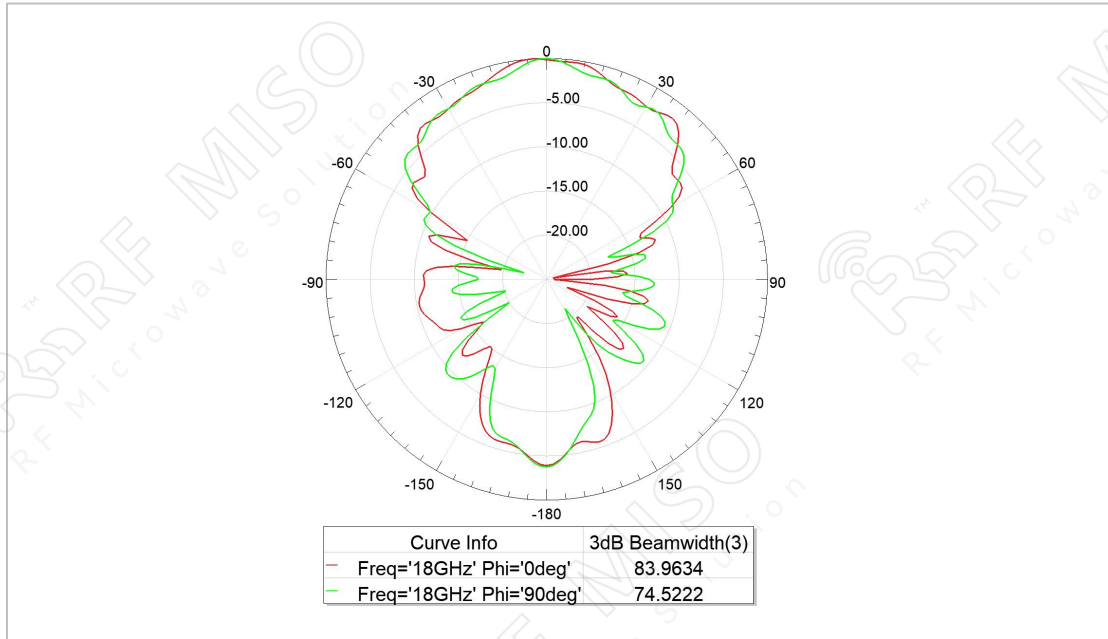

18 GHz