

*Broadband Dual Polarized Horn Antenna
15dBi Typ. Gain, 1-30 GHz Frequency Range*

Broadband Dual Polarized Horn Antenna Data

RM-BDPHA130-15

Features

- Full Band Performance
- Dual Polarization
- High Isolation
- Weight Reduction Design

Description

The **RM-BDPHA130-15** is a full-band, dual-polarized horn antenna assembly that operates in the frequency range of 1 to 30 GHz. The antenna offers a typical gain of 15 dBi and low VSWR 1.5 Typ. The antenna can be widely used in EMI detection, orientation, reconnaissance, antenna gain and pattern measurement and other application fields.

Specifications

RM-BDPHA130-15		
Item	Specification	Units
Frequency Range	1-30	GHz
Gain	15 Typ.	dBi
VSWR	1.5 Typ.	
Polarization	Dual	
Cross Pol. Isolation	35 Typ.	dB
3dB Beamwidth, E-Plane	6.43~81.61	°
3dB Beamwidth, H-Plane	5.47~141.69	°
Connector	SMA-Female	
Size(L*W*H)	Ø172.5*177.8(±5)	mm
Weight	1.037	Kg
Material and Finish	Al, Paint	
Power Handling, CW	50	W
Power Handling, Peak	100	W

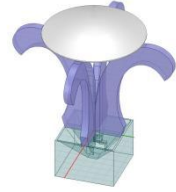

Broadband Dual Polarized Horn Antenna
15dBi Typ.Gain, 1-30 GHz Frequency Range

Broadband Dual Polarized Horn Antenna Data

RM-BDPHA130-15

Outline Drawing

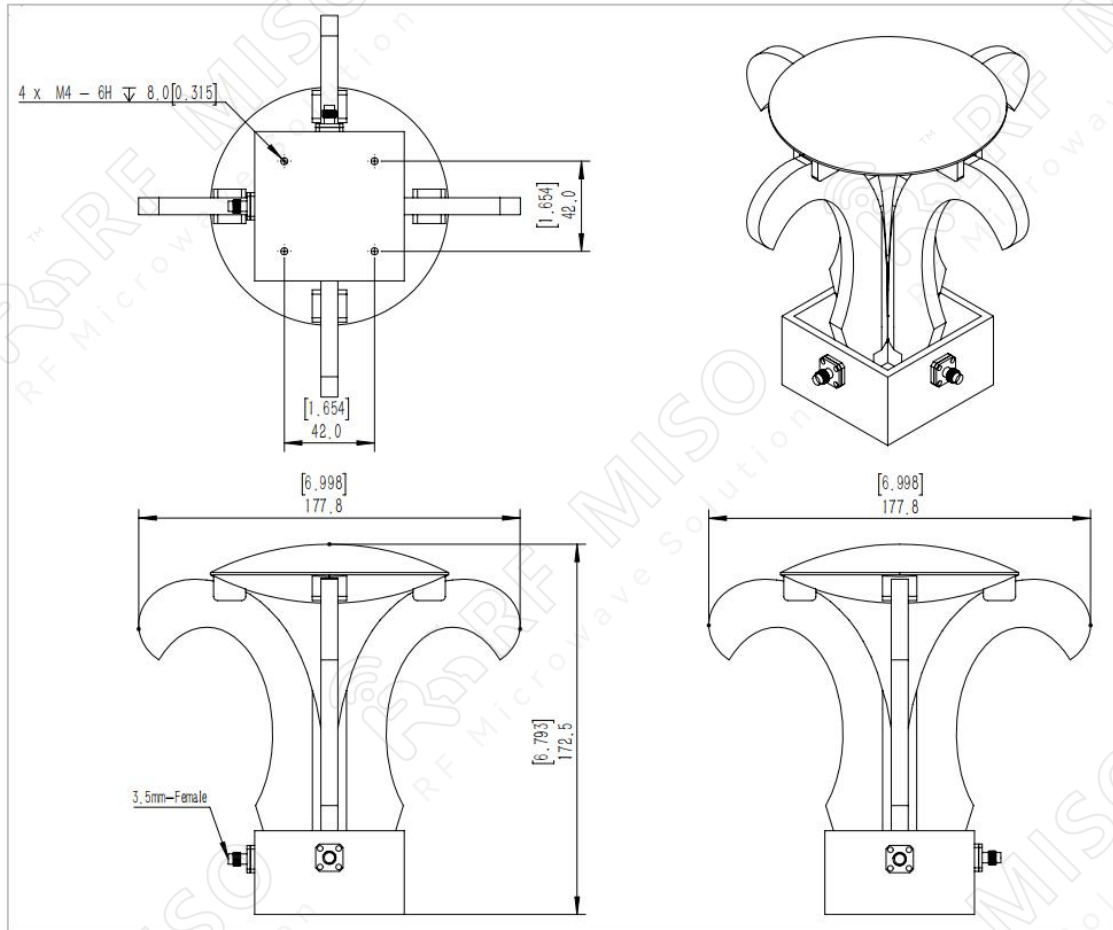

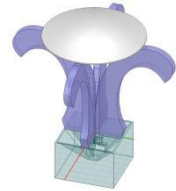

Broadband Dual Polarized Horn Antenna
15dBi Typ. Gain, 1-30 GHz Frequency Range

Broadband Dual Polarized Horn Antenna Data

RM-BDPHA130-15

Simulated Data

VSWR

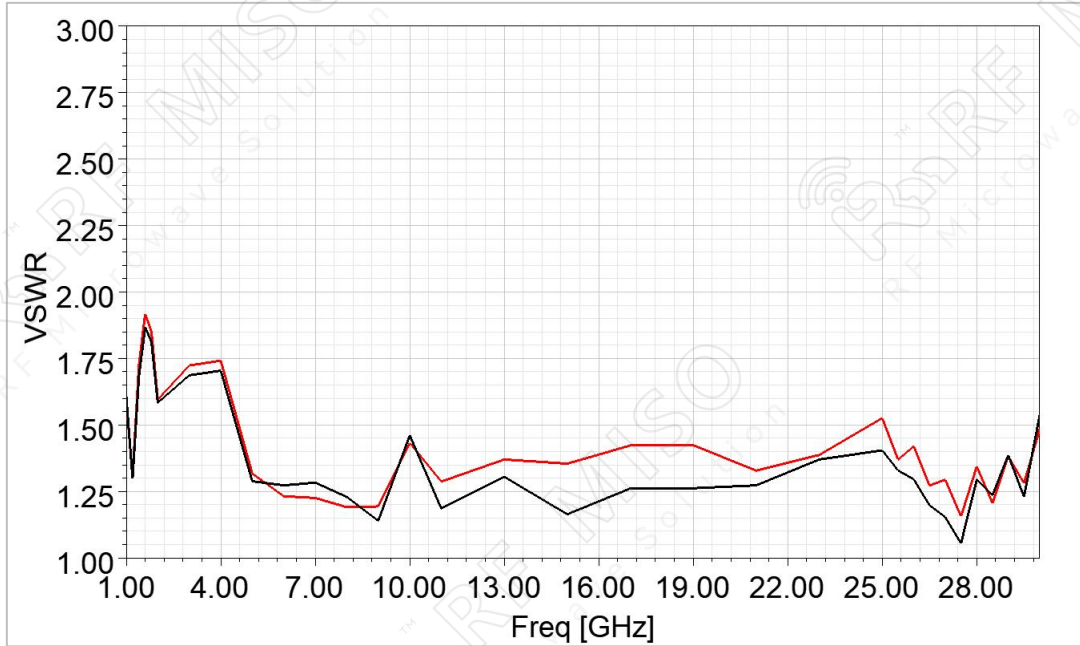

Gain

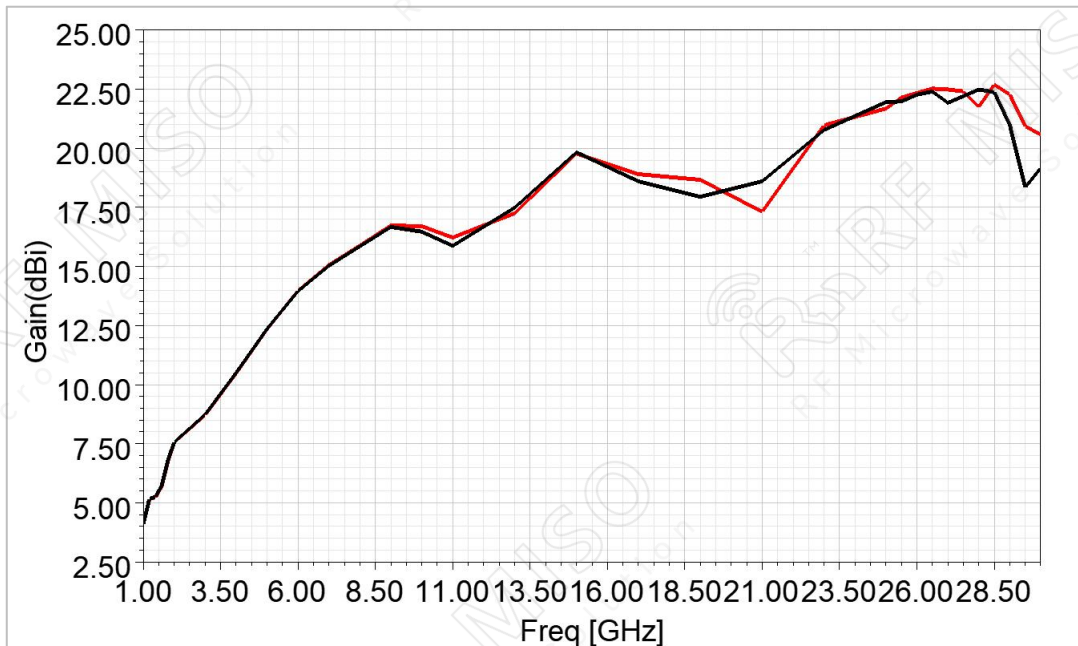

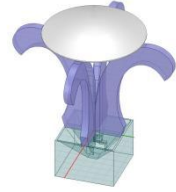

Broadband Dual Polarized Horn Antenna
15dBi Typ. Gain, 1-30 GHz Frequency Range

Broadband Dual Polarized Horn Antenna Data

RM-BDPHA130-15

Cross Pol. Isolation



3dB Beamwidth

E-Plane

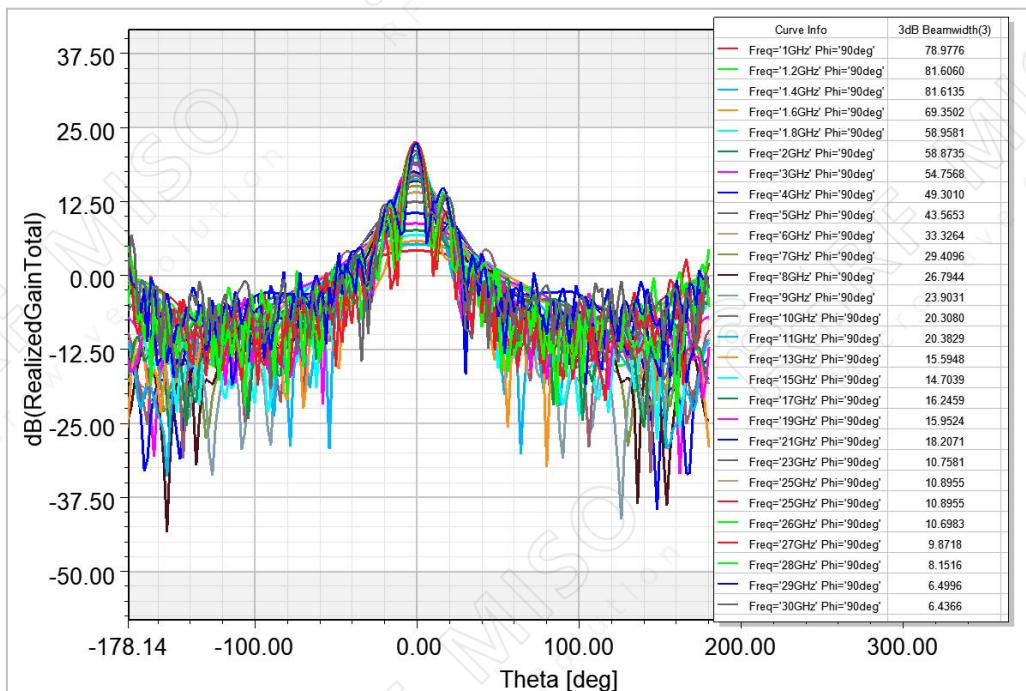

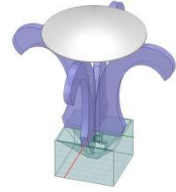

Broadband Dual Polarized Horn Antenna
15dBi Typ. Gain, 1-30 GHz Frequency Range

Broadband Dual Polarized Horn Antenna Data

RM-BDPHA130-15

H-Plane

